

# Fitment of Rail Burner into Warmington Open Fire

**STEP 1**

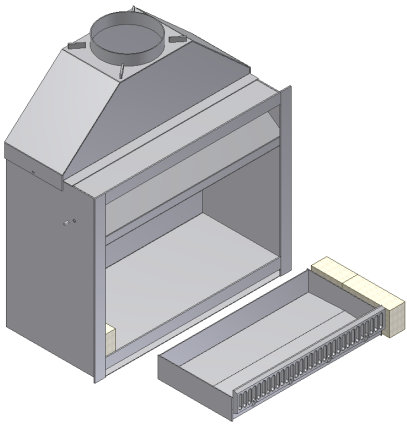

Remove Ash Pan & Front & Back Bricks from Firebox

**STEP 2**

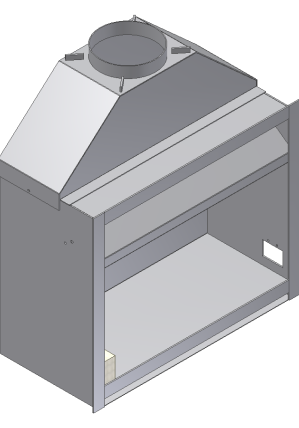

**HOLE LAYOUT FOR RAIL BURNER**

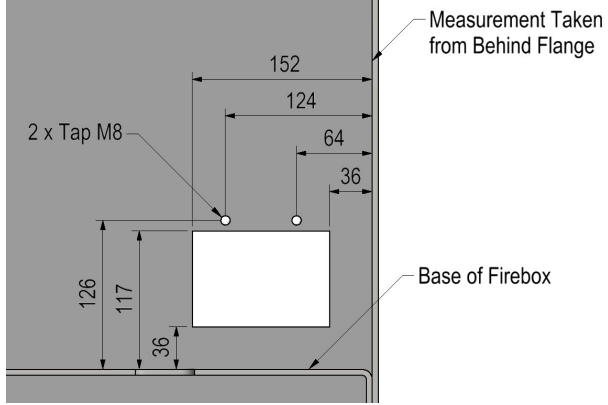

Cut Out Holes and Square to Fit Rail Burner - See Hole Layout

**STEP 3**

Put Ash Pan & bricks back in the Firebox.

**STEP 4**

Fit Gas Rail Burner into the Firebox.

# Fitment of Gas Flare into Warmington Open Fire

**STEP 1**

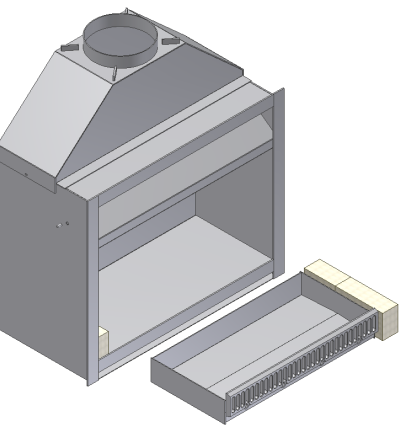

Remove Ash Pan & Bricks from Firebox

**STEP 2**

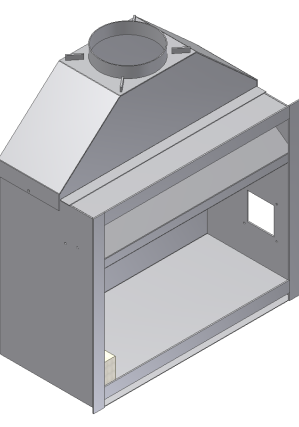

**HOLE LAYOUT FOR FLARE BURNER**

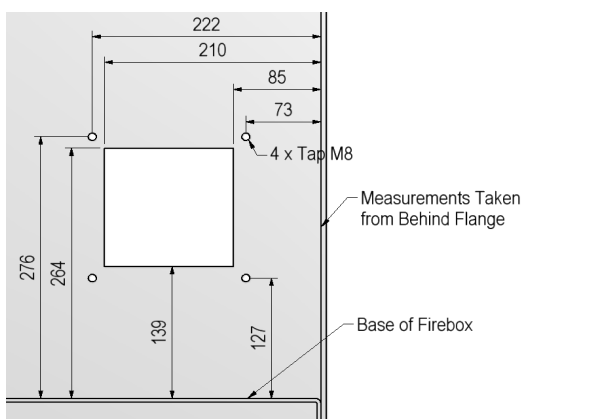

Cut Out Holes and Square to Fit Gas Flare - See Hole Layout

**STEP 3**

Put Ash Pan & bricks back in the Firebox.

**STEP 4**

Fit Gas Flare into Firebox.

Due to continued product improvement, Warmington Ind LTD reserves the right to change product specifications without prior notification.