

# Warmington Gas Open Fire

## Debonair Virage 1200 LH

Fire, Flue System to Comply with NZS 5261 / 5262 : 2003

**Due to continued product improvement, Warmington Ind LTD reserves the right to change product specifications without prior notification.**

Read all the Instructions carefully before commencing the Installation. Failure to follow these instructions may result in a fire hazard and void the warranty

For Specification See: [www.warmington.co.nz](http://www.warmington.co.nz)

Copyright ©

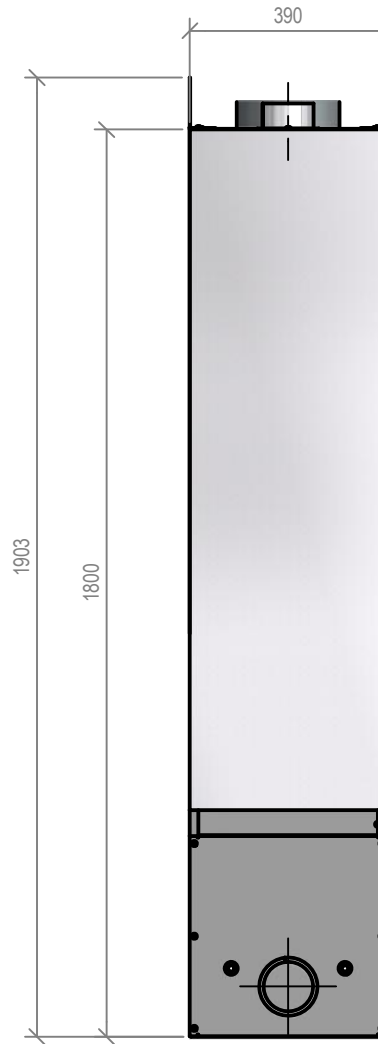
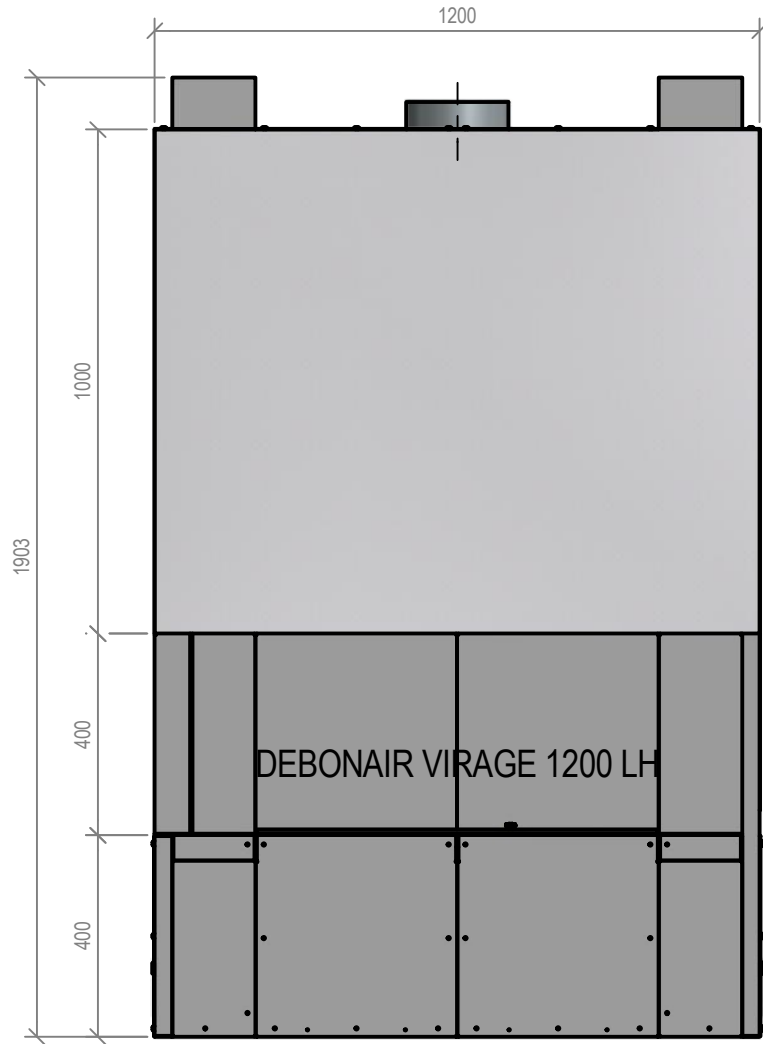

<b>Warmington Industries Ltd.</b>	
PH: 09 273 9227 FAX: 09 273 9241 WEB: <a href="http://www.warmington.co.nz">www.warmington.co.nz</a>	
TITLE	DEBONAIR VIRAGE 1200 LH
DRAWN	ROBERT
DATE	13/02/14
SCALE	NOT TO SCALE
REVISION	01

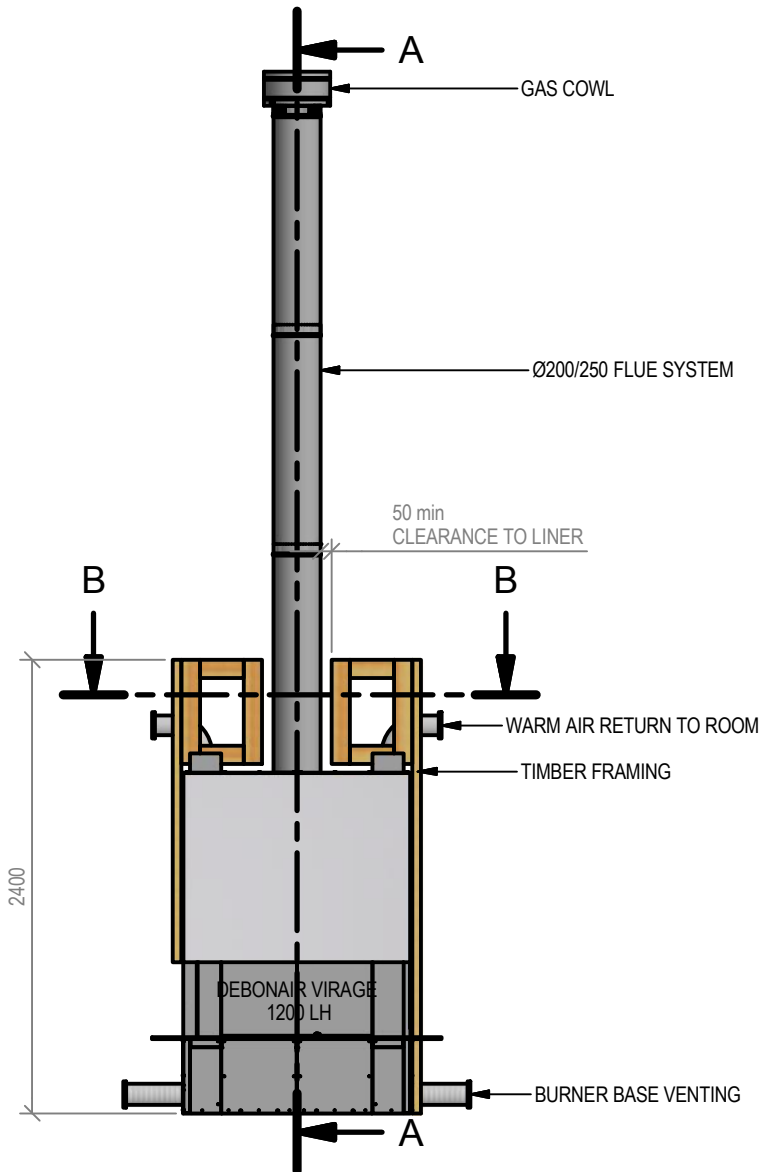
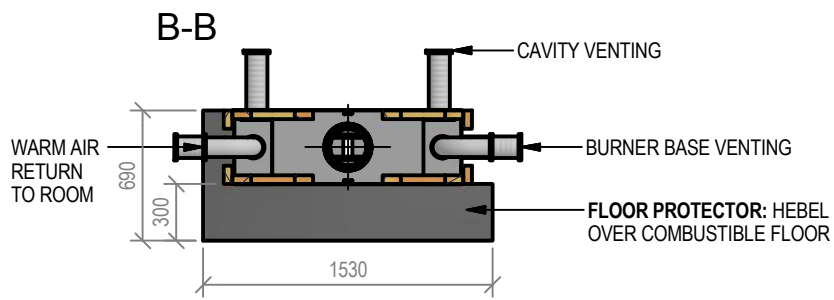

**IMPORTANT NOTE:**  
 WHERE AN INTERNAL WALL BOARD FINISH IS REQUIRED AROUND THE FIREPLACE, ENSURE ALLOWANCE IS MADE TO PLACE NON COMBUSTIBLE INTERNAL WALL LINING (e.g. PROMINA ETERPAN, SUPALUX) TO COVER THE EXTENT OF THE HEBEL BLOCK SURROUND

DIRECTLY TOUCHING THE FIREBOX WITH ANY BOARD OR PLASTER MAY CAUSE CRACKING FROM HEAT EXPANSION  
 ALLOW 3mm MINIMUM SPACE AWAY FROM THE FIREBOX

**NOTE:**  
 WARMINGTON CAITEC AIR IS REQUIRED  
 SEE SPECIFIC INSTALL INSTRUCTION

A-A

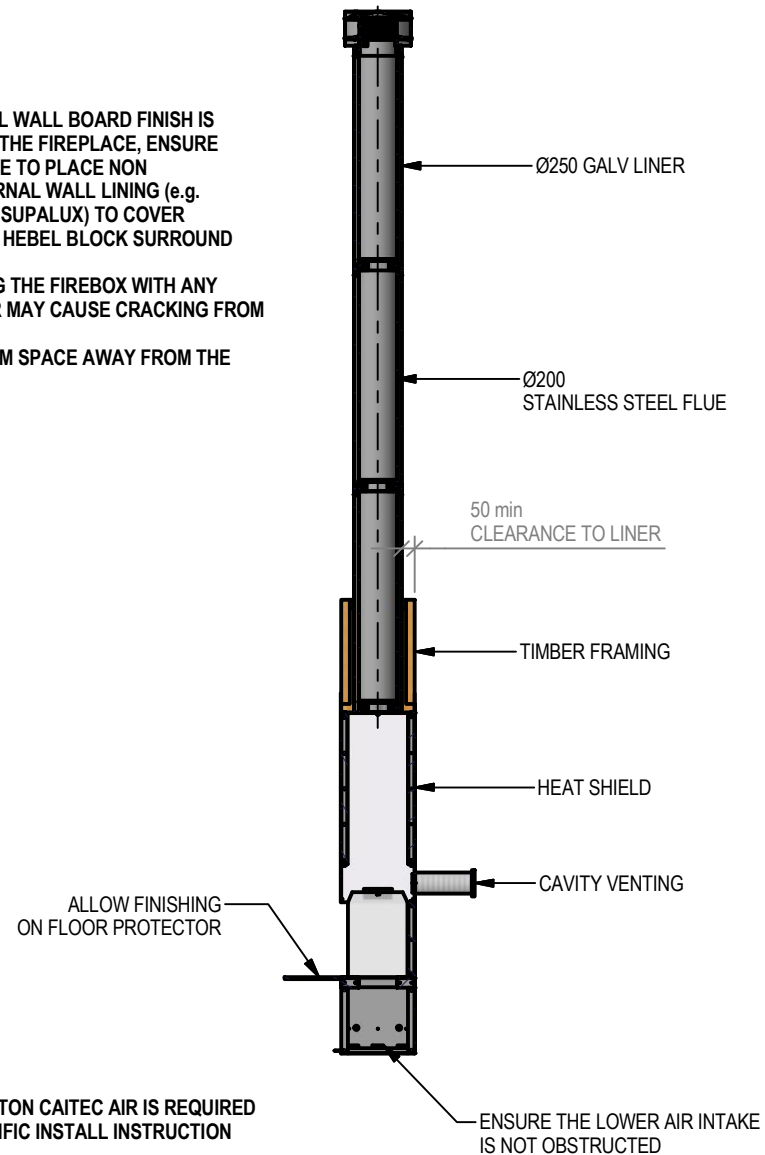

# Warmington Gas Open Fire

## Debonair Virage 1200 LH Timber Framing

Fire, Flue System to Comply with NZS 5261 / 5262 : 2003

**Due to continued product improvement, Warmington Ind LTD reserves the right to change product specifications without prior notification.**

Read all the Instructions carefully before commencing the Installation. Failure to follow these instructions may result in a fire hazard and void the warranty

For Specification See: [www.warmington.co.nz](http://www.warmington.co.nz)

Copyright ©

<b>Warmington Industries Ltd.</b>			
PH: 09 273 9227 FAX: 09 273 9241 WEB: <a href="http://www.warmington.co.nz">www.warmington.co.nz</a>			
TITLE	DEBONAIR VIRAGE 1200 LH TIMBER FRAMING	DATE	13/02/14
DRAWN	ROBERT	SCALE	NOT TO SCALE
SCALE	NOT TO SCALE	REVISION	01