

# Warmington Gas Open Fire

## Duplo 1600 Firebox

Fire, Flue system to comply with NZS 5261 / 5262 : 2003

**Due to continued product development, Warmington Ind LTD reserves the right to change product specifications without prior notification.**

Read all the instructions carefully before commencing the installation. Failure to follow these instructions may result in a fire hazard and void the warranty.

For specification see: [www.warmington.co.nz](http://www.warmington.co.nz)

Copyright ©

<b>Warmington Industries Ltd.</b>	
PH: 09 273 9227 FAX: 09 273 9241 WEB: <a href="http://www.warmington.co.nz">www.warmington.co.nz</a>	
TITLE Duplo 1600 Firebox	DATE 10-12-18
DRAWN Ben	REVISION 01
SCALE Not to scale	

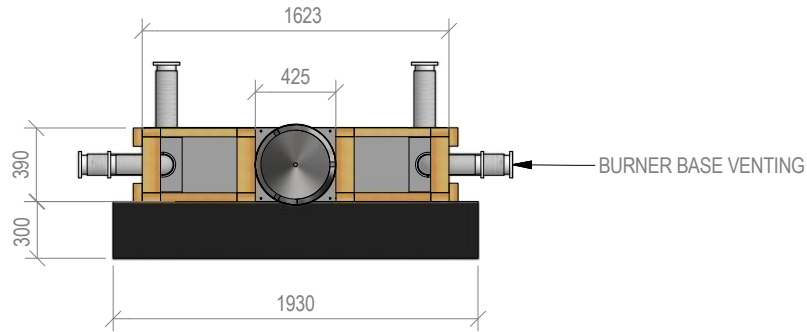

# Warmington Gas Open Fire

Duplo 1600 Firebox Timber Framing

Fire, flue system to comply with NZS 5261 / 5262 : 2003

**Due to continued product development, Warmington Ind LTD reserves the right to change product specifications without prior notification.**

Read all the instructions carefully before commencing the installation. Failure to follow these instructions may result in a fire hazard and void the warranty.

For specification see: [www.warmington.co.nz](http://www.warmington.co.nz)

Copyright ©

**IMPORTANT NOTE:**

WHERE AN INTERNAL WALL BOARD FINISH IS REQUIRED AROUND THE FIREPLACE, ENSURE ALLOWANCE IS MADE TO PLACE NON COMBUSTIBLE INTERNAL WALL LINING (CALCIUM SILICATE BOARD, EQUIVALENT TO 0.136 w/mk) TO COVER THE EXTENT OF THE HEBEL BLOCK SURROUND.

DIRECTLY TOUCHING THE FIREBOX WITH ANY BOARD OR PLASTER MAY CAUSE CRACKING FROM HEAT EXPANSION. ALLOW 3mm MINIMUM SPACE AWAY FROM THE FIREBOX.

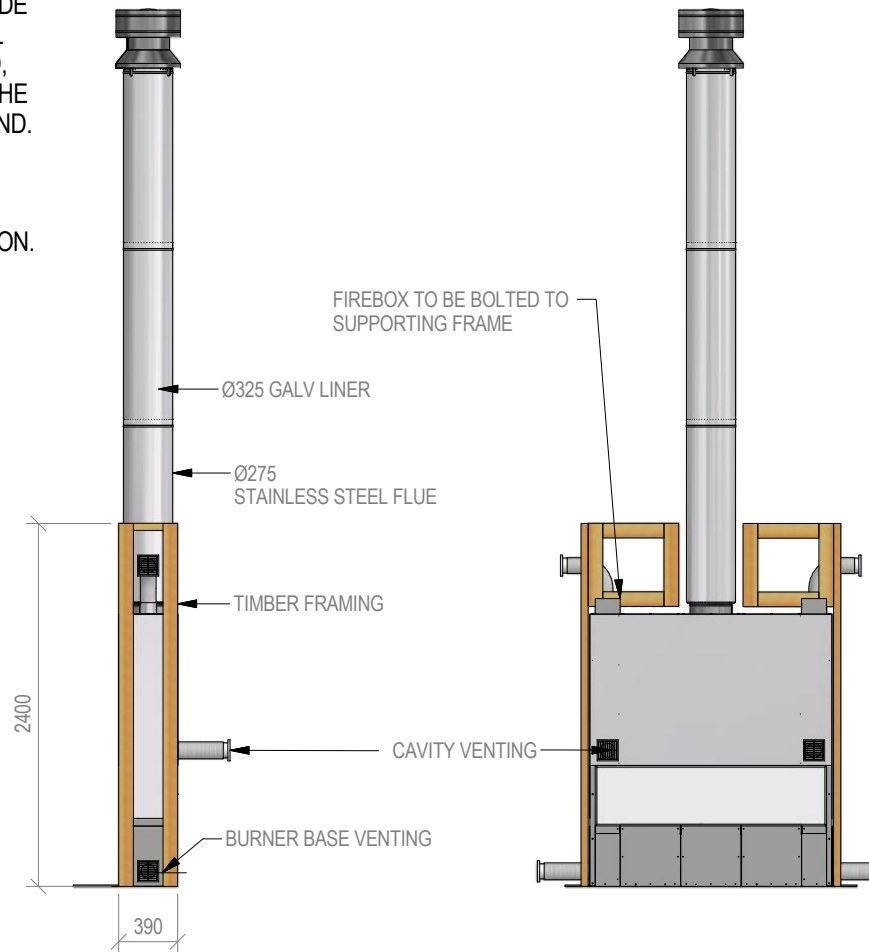
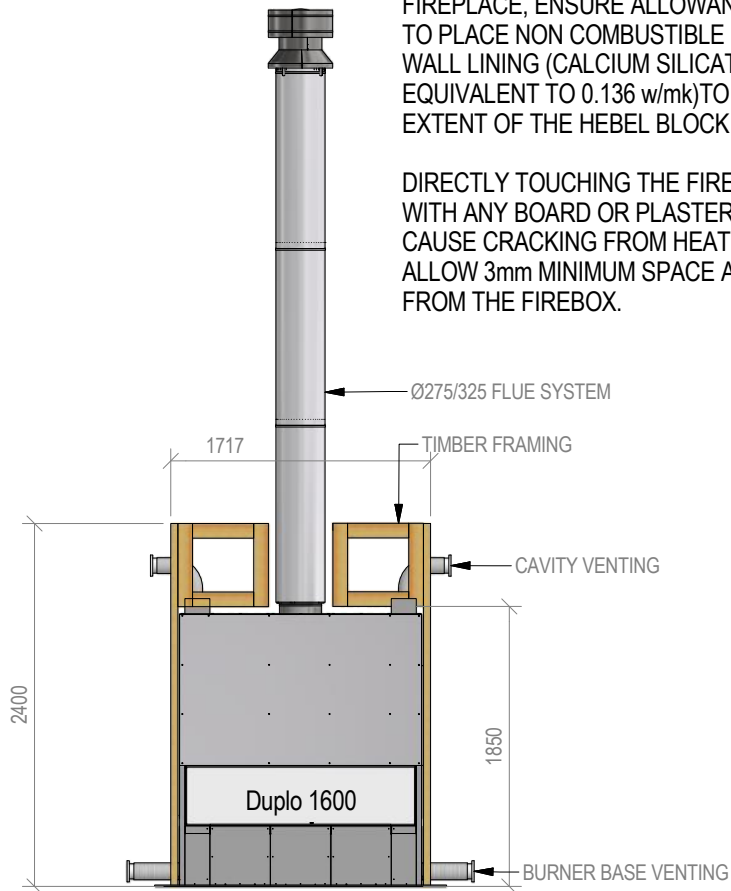

<b>Warmington Industries Ltd.</b>	
PH: 09 273 9227 FAX: 09 273 9241 WEB: <a href="http://www.warmington.co.nz">www.warmington.co.nz</a>	
TITLE	Duplo 1600 Timber Framing
DRAWN	Ben
DATE	10-12-18
SCALE	Not to scale
REVISION	01