

# Warmington Outdoor Wood Fire

SN 1100 Pizzeria Firebox Double Flue

NOTE: Requires Hebel Enclosure

Fire,Flue System to Comply with ASNZS 2918:2001

**Due to continued product improvement, Warmington Ind LTD reserves the right to change product specification without prior notification.**

Read all the instructions carefully before commencing the Installation. Failure to follow these instructions may result in a fire hazard and void the warranty

For Specification See: [www.warmington.co.nz](http://www.warmington.co.nz)

Copyright ©

NOTE: Engineering Calculations may be required

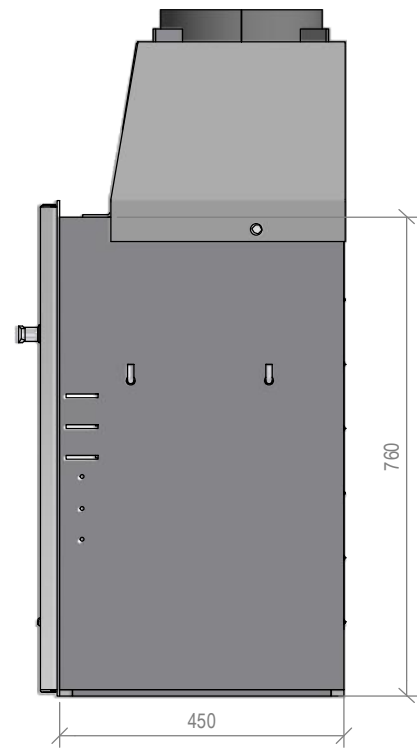
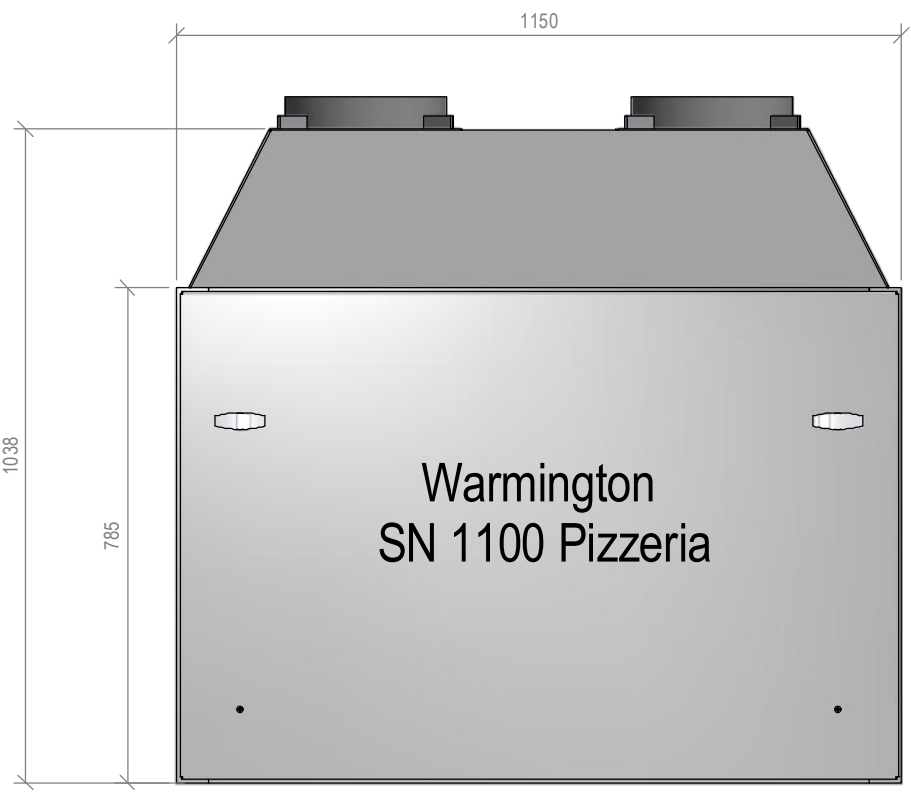

<b>Warmington Industries Ltd.</b>	
PH: 09 273 9227 FAX: 09 273 9241 WEB: <a href="http://www.warmington.co.nz">www.warmington.co.nz</a>	
TITLE	SN 1100 Double Flue Pizzeria Firebox
DRAWN	Robert
DATE	24/04/18
SCALE	1/12
REVISION	01

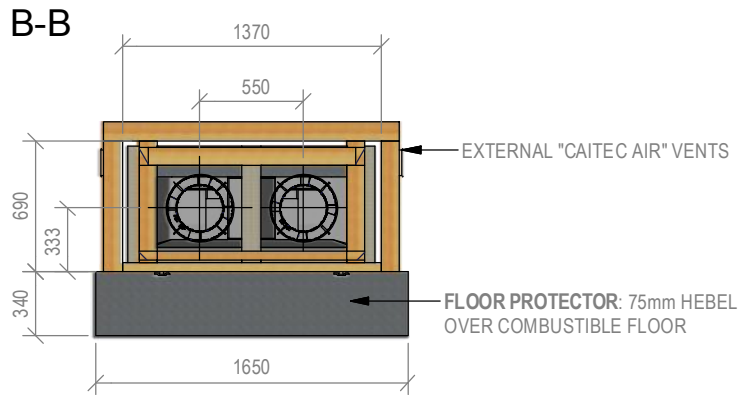

# Warmington Outdoor Wood Fire

## SN 1100 Pizzeria Firebox Double Flue Timber Framing

NOTE: Requires Hebel Enclosure

Fire,Flue System to Comply with ASNZS 2918:2001

**Due to continued product improvement, Warmington Ind LTD reserves the right to change product specification without prior notification.**

Read all the instructions carefully before commencing the Installation. Failure to follow these instructions may result in a fire hazard and void the warranty

For Specification See: [www.warmington.co.nz](http://www.warmington.co.nz)

Copyright ©

NOTE: Engineering Calculations may be required

**IMPORTANT NOTE:**  
 WHERE AN INTERNAL WALL BOARD FINISH IS REQUIRED AROUND THE FIREPLACE, ENSURE ALLOWANCE IS MADE TO PLACE NON COMBUSTIBLE INTERNAL WALL LINING (E.G. PROMINA ETERPAN, SUPALUX) TO COVER THE EXTENT OF THE HEBEL BLOCK SURROUND.

**DIRECTLY TOUCHING THE FIREBOX WITH ANY BOARD OR PLASTER MAY CAUSE CRACKING FROM HEAT EXPANSION. ALLOW 3mm MINIMUM SPACE AWAY FROM THE FIREBOX.**

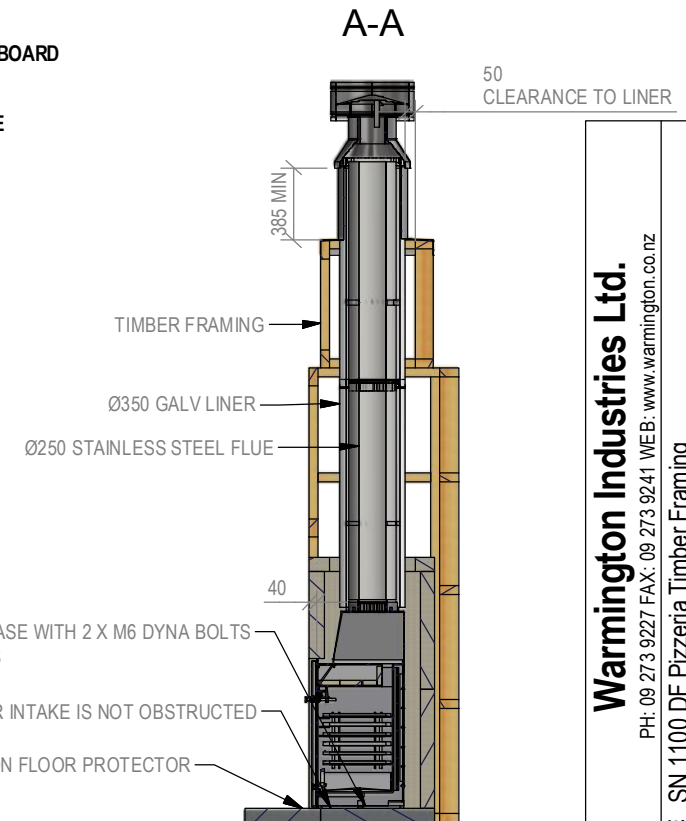
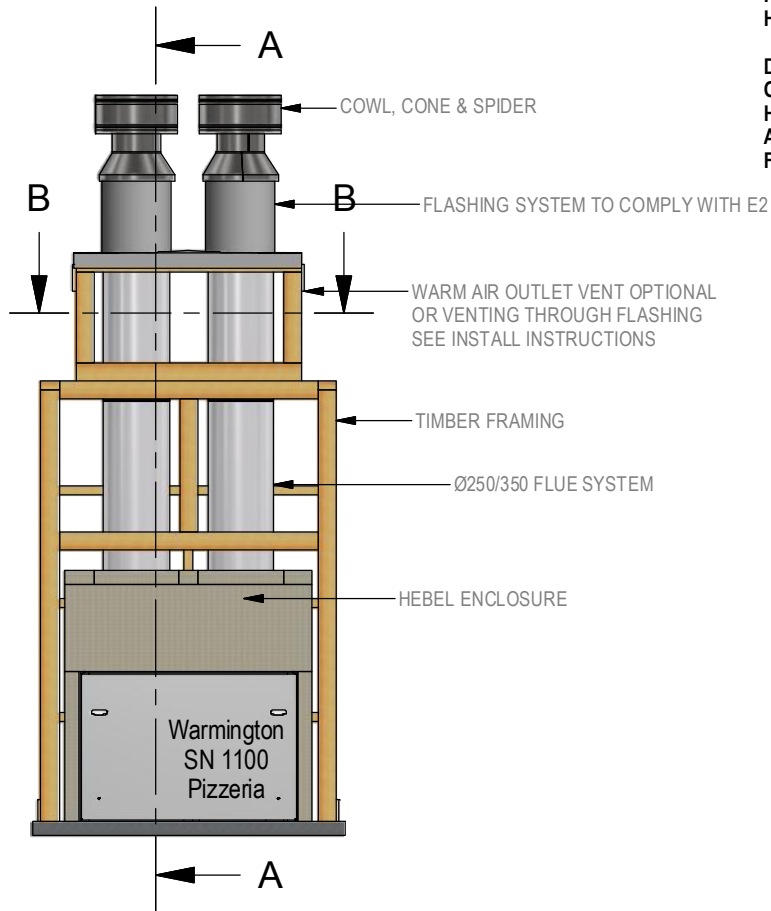

SECURE FIRE TO BASE WITH 2 X M6 DYNA BOLTS  
 SEE INSTRUCTIONS

ENSURE LOWER AIR INTAKE IS NOT OBSTRUCTED

ALLOW FINISHING ON FLOOR PROTECTOR

**Note:**  
**WARMINGTON CAITEC AIR IS REIURED**  
**SEE SPECIFIC INSTALL INSTRUCTION**

<b>Warmington Industries Ltd.</b>	
PH: 09 273 9227 FAX: 09 273 9241 WEB: <a href="http://www.warmington.co.nz">www.warmington.co.nz</a>	
TITLE SN 1100 DF Pizzeria Timber Framing	
DRAWN Robert	DATE 1/05/18
SCALE 1/35	REVISION 01

B-B

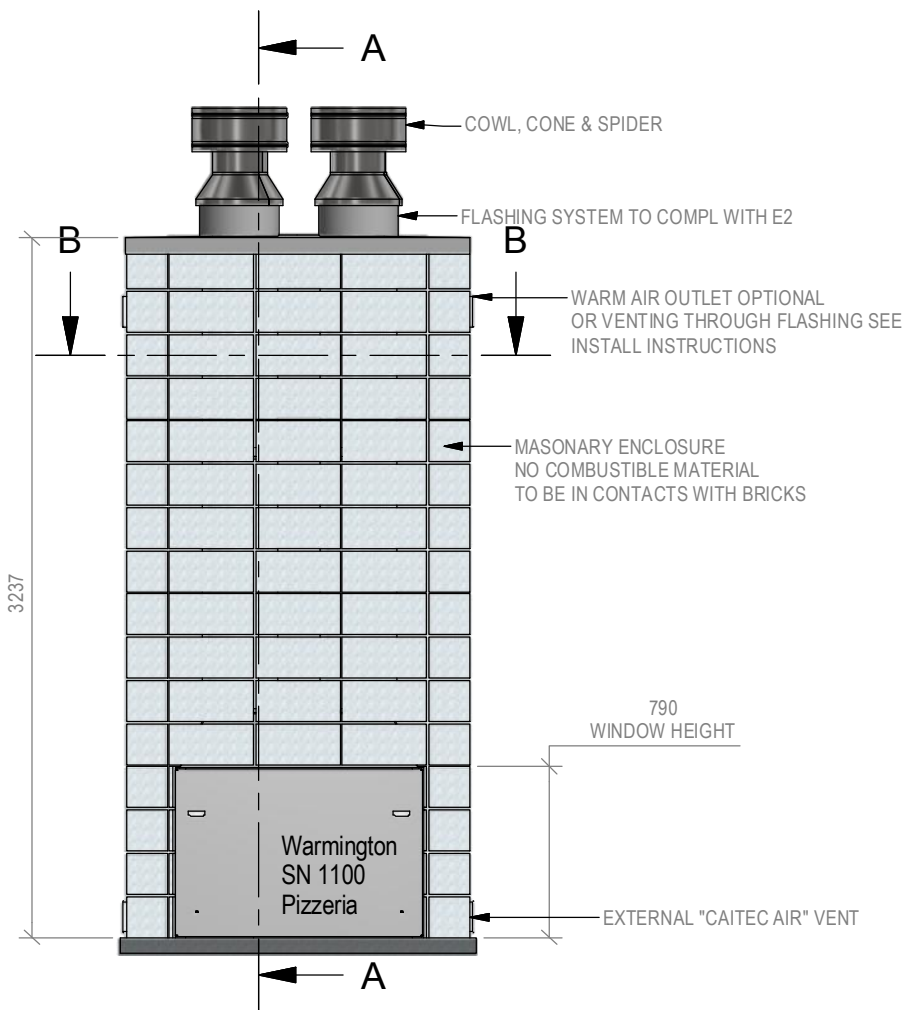
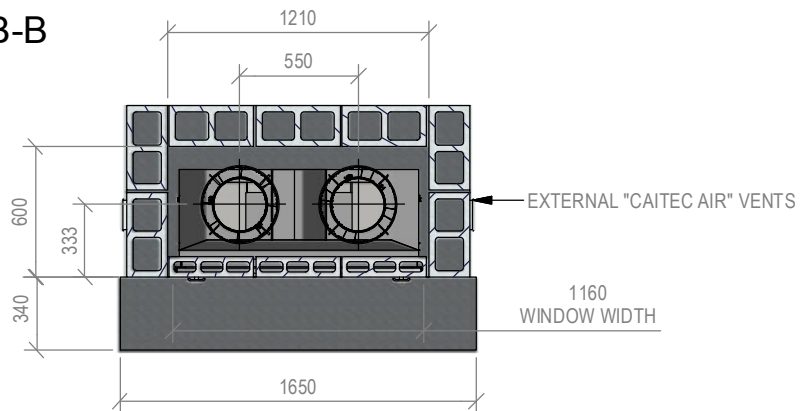

# Warmington Outdoor Wood Fire

SN 1100 Pizzeria Firebox Double Flue Block Enclosure

NOTE: Requires Hebel Enclosure

Fire,Flue System to Comply with ASNZS 2918:2001

**Due to continued product improvement, Warmington Ind LTD reserves the right to change product specification without prior notification.**

Read all the instructions carefully before commencing the Installation. Failure to follow these instructions may result in a fire hazard and void the warranty

For Specification See: [www.warmington.co.nz](http://www.warmington.co.nz)

Copyright ©

NOTE: Engineering Calculations may be required

**IMPORTANT NOTE:**

WHERE AN INTERNAL WALL BOARD FINISH IS REQUIRED AROUND THE FIREPLACE, ENSURE ALLOWANCE IS MADE TO PLACE NON COMBUSTIBLE INTERNAL WALL LINING (E.G. PROMINA ETERPAN, SUPALUX) TO COVER THE EXTENT OF THE HEBEL BLOCK SURROUND.

DIRECTLY TOUCHING THE FIREBOX WITH ANY BOARD OR PLASTER MAY CAUSE CRACKING FROM HEAT EXPANSION. ALLOW 3mm MINIMUM SPACE AWAY FROM THE FIREBOX.

A-A

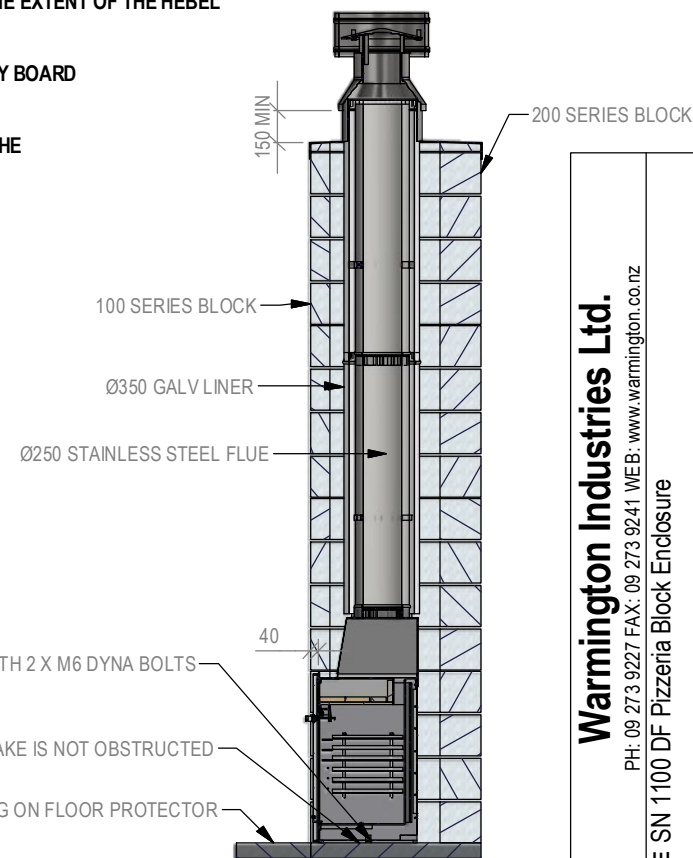

**Note:**

**WARMINGTON CAITEC AIR IS REUIRED SEE SPECIFIC INSTALL INSTRUCTION**

<b>Warmington Industries Ltd.</b>	
PH: 09 273 9227 FAX: 09 273 9241 WEB: <a href="http://www.warmington.co.nz">www.warmington.co.nz</a>	
TITLE SN 1100 DF Pizzeria Block Enclosure	
DRAWN Robert	DATE 24/04/18
SCALE 1/35	REVISION 01