

Warmington Open Wood Fire

SN 1100 Firebox Double Flue

NOTE: Requires Hebel Enclosure

Fire, Flue System to Comply with AS/NZS 2918:2001

Due to continued product improvement, Warmington LTD reserves the right to change product specification without prior notification.

Read all the Instructions carefully before commencing the Installation. Failure to follow these instructions may result in a fire hazard and void the warranty

For Specification See: www.warmington.co.nz

Copyright ©

NOTE: Engineering Calculations may be required

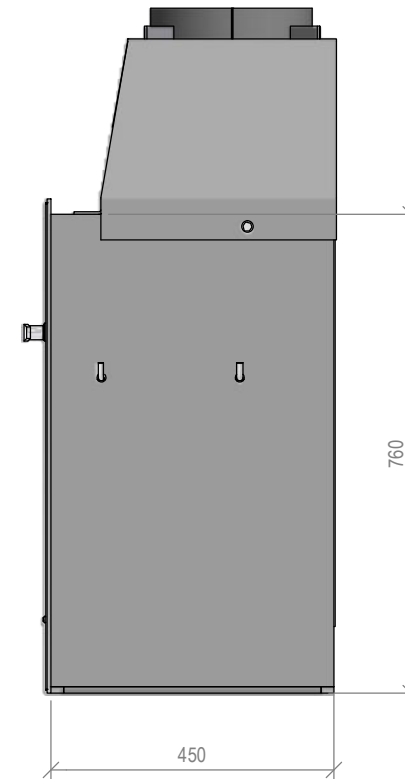
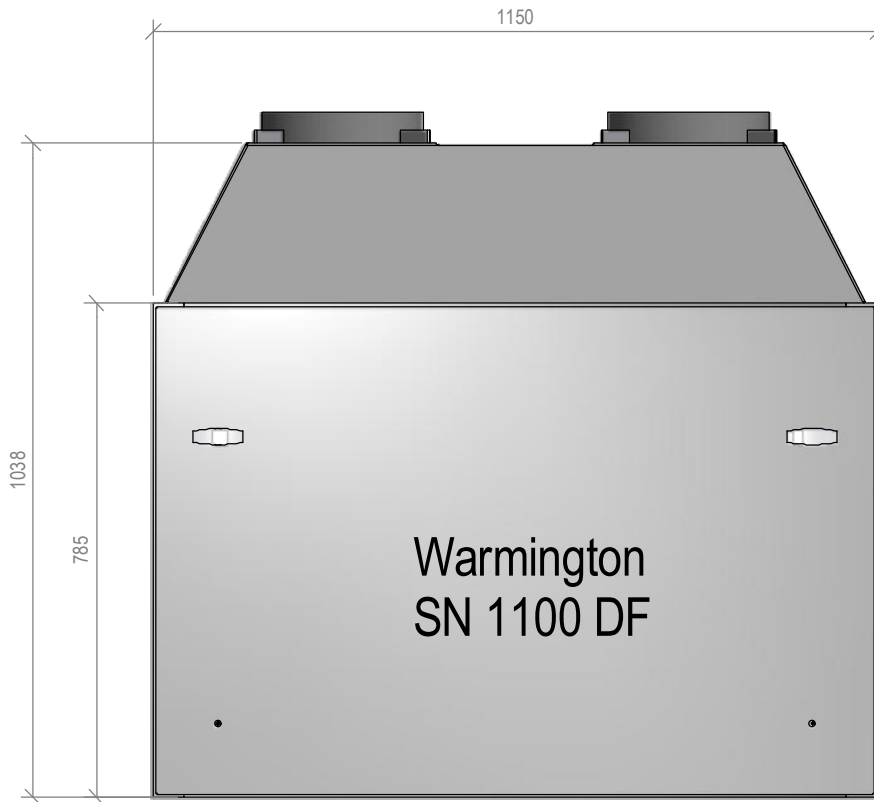

Warmington Industries Ltd.	
PH: 09 273 9227 FAX: 09 273 9241 WEB: www.warmington.co.nz	
TITLE SN 1100 Firebox Double Flue	
DRAWN Robert	DATE 26/04/18
SCALE 1/12	REVISION 01

Warmington Open Wood Fire

SN 1100 Firebox Double Flue Timber Framing

NOTE: Requires Hebel Enclosure
Fire, Flue System to Comply with ASNZS 2918:2001

Due to continued product improvement, Warmington LTD reserves the right to change product specification without prior notification.

Read all the Instructions carefully before commencing the Installation. Failure to follow these instructions may result in a fire hazard and void the warranty
For Specification See: www.warmington.co.nz
Copyright ©

NOTE: Engineering Calculations may be required

IMPORTANT NOTE:
WHERE AN INTERNAL WALL BOARD FINISH IS REQUIRED AROUND THE FIREPLACE, ENSURE ALLOWANCE IS MADE TO PLACE NON COMBUSTIBLE INTERNAL WALL LINING (e.g. PROMINA ETERPAN, SUPALUX) TO COVER THE EXTENT OF THE HEBEL BLOCK SURROUND.

DIRECTLY TOUCHING THE FIREBOX WITH ANY BOARD OR PLASTER MAY CAUSE CRACKING FROM HEAT EXPANSION.
ALLOW 3mm MINIMUM SPACE AWAY FROM THE FIREBOX.

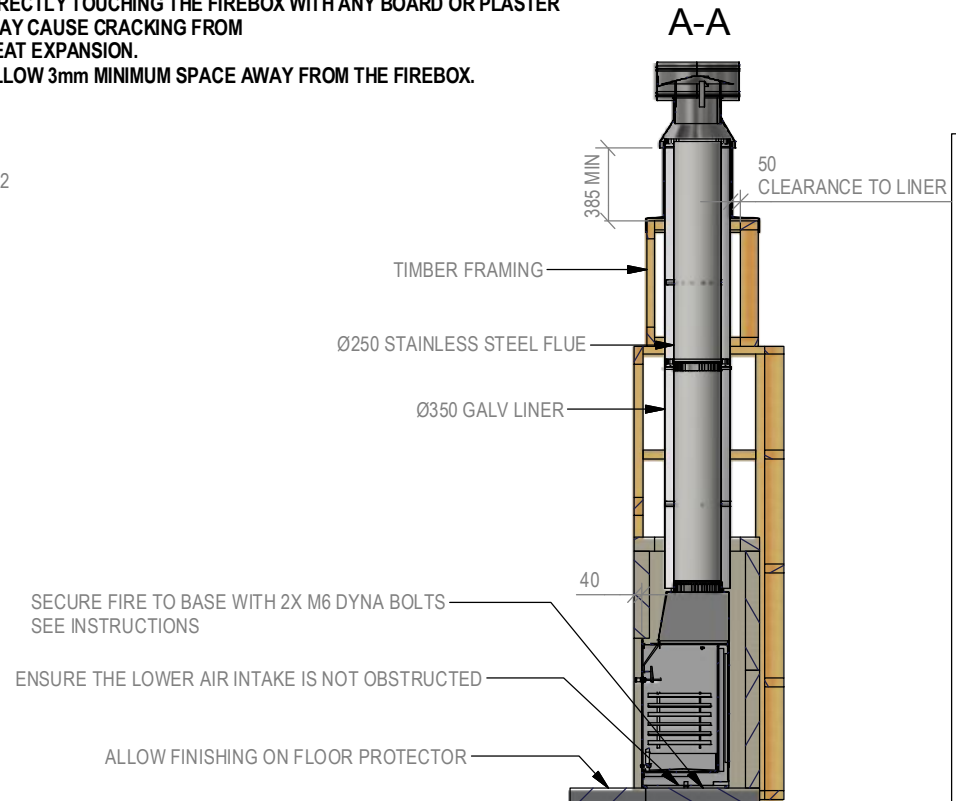
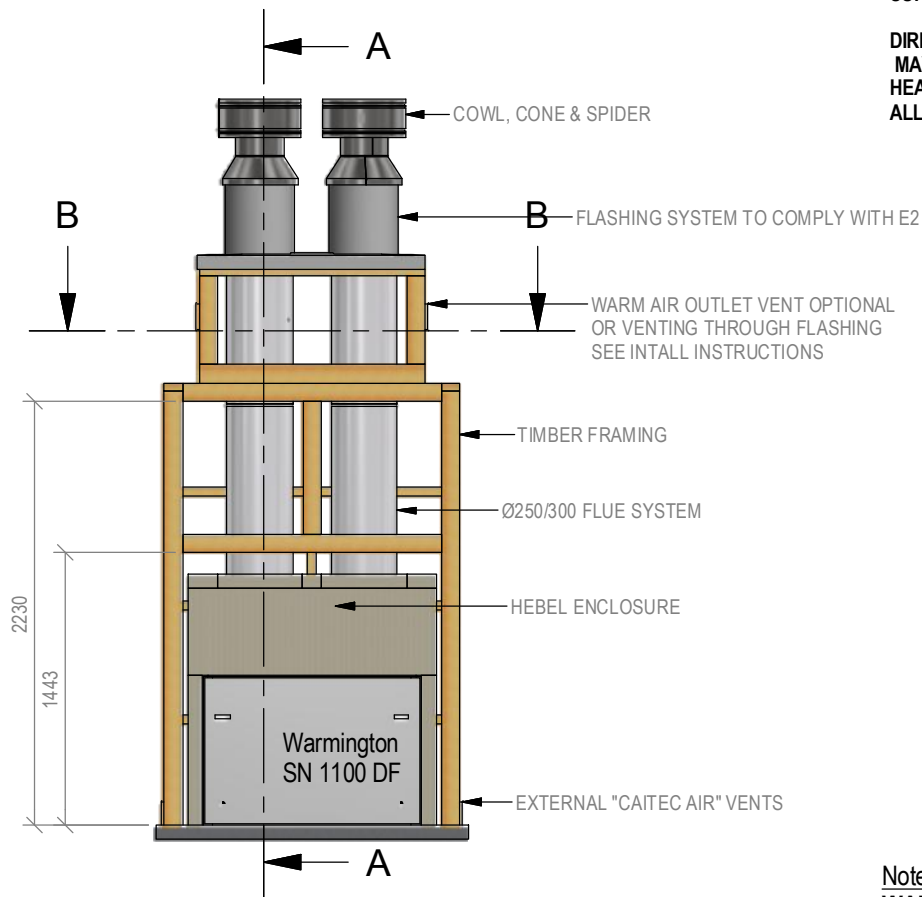
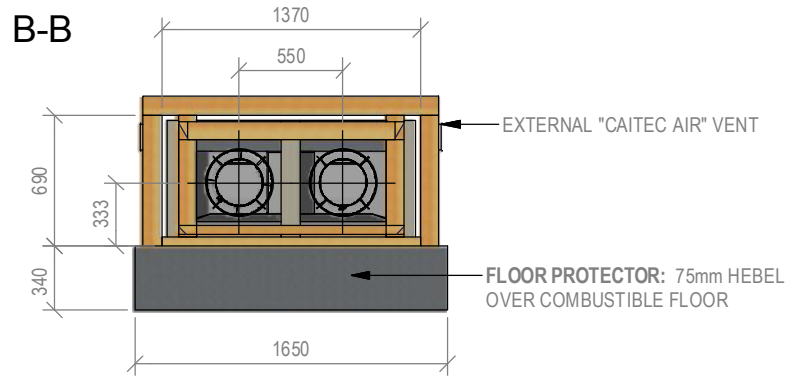

Note:
WARMINGTON CAITEC AIR IS REQUIRED SEE SPECIFIC INSTALL INSTRUCTIONS

Warmington Industries Ltd.	
PH: 09 273 9227 FAX: 09 273 9241 WEB: www.warmington.co.nz	
TITLE	SN 1100 Firebox Double Flue Timber Framing
DRAWN	Robert
DATE	26/04/18
SCALE	1/35
REVISION	01

B-B

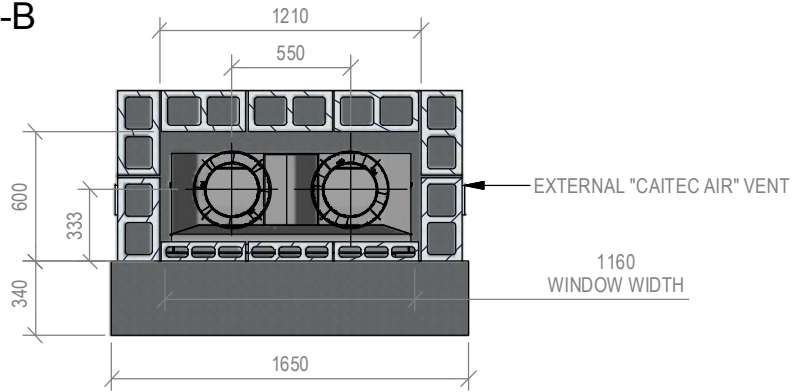

Warmington Open Wood Fire

SN 1100 Firebox Double Flue Block Enclosure

NOTE: Requires Hebel Enclosure

Fire, Flue System to Comply with AS/NZS 2918:2001

Due to continued product improvement, Warmington LTD reserves the right to change product specification without prior notification.

Read all the Instructions carefully before commencing the Installation. Failure to follow these instructions may result in a fire hazard and void the warranty

For Specification See: www.warmington.co.nz

Copyright ©

NOTE: Engineering Calculations may be required

IMPORTANT NOTE:

WHERE AN INTERNAL WALL BOARD FINISH IS REQUIRED AROUND THE FIREPLACE, ENSURE ALLOWANCE IS MADE TO PLACE NON COMBUSTIBLE INTERNAL WALL LINING (e.g. PROMINA ETERPAN, SUPALUX) TO COVER THE EXTENT OF THE HEBEL BLOCK SURROUND.

DIRECTLY TOUCHING THE FIREBOX WITH ANY BOARD OR PLASTER MAY CAUSE CRACKING FROM HEAT EXPANSION. ALLOW 3mm MINIMUM SPACE AWAY FROM THE FIREBOX.

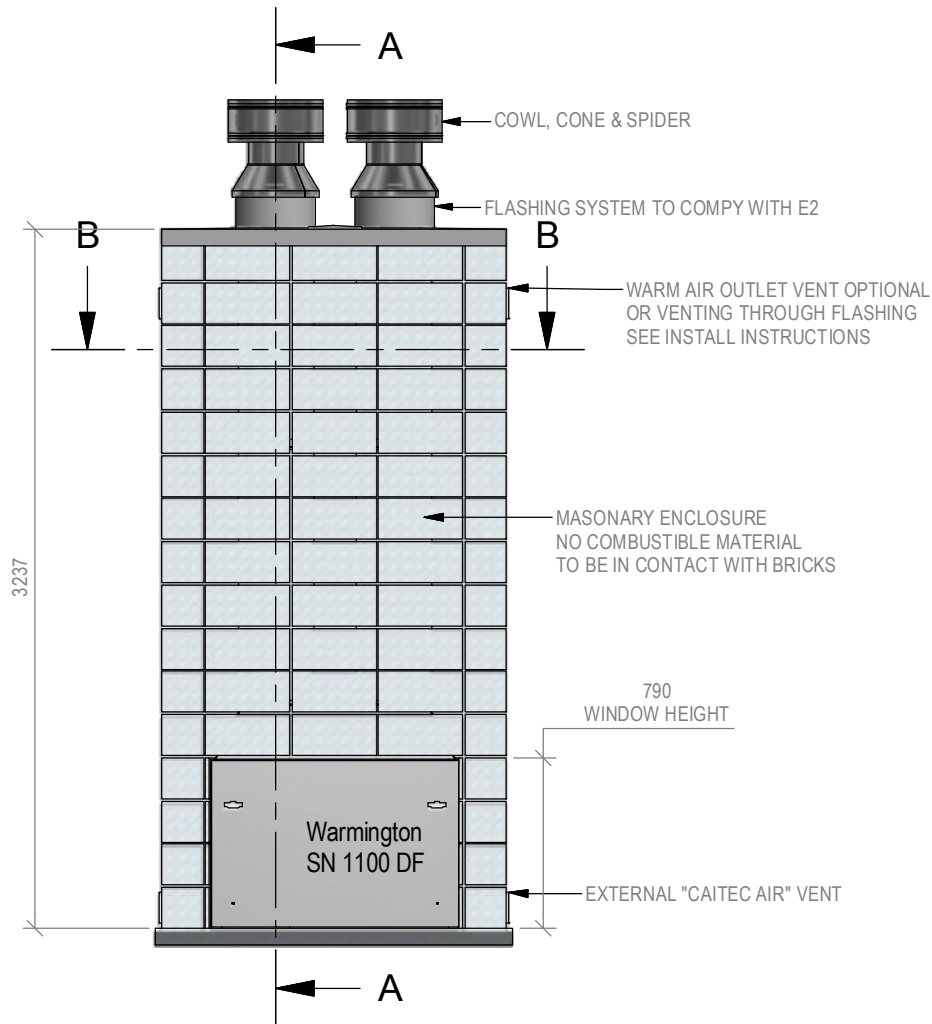

A-A

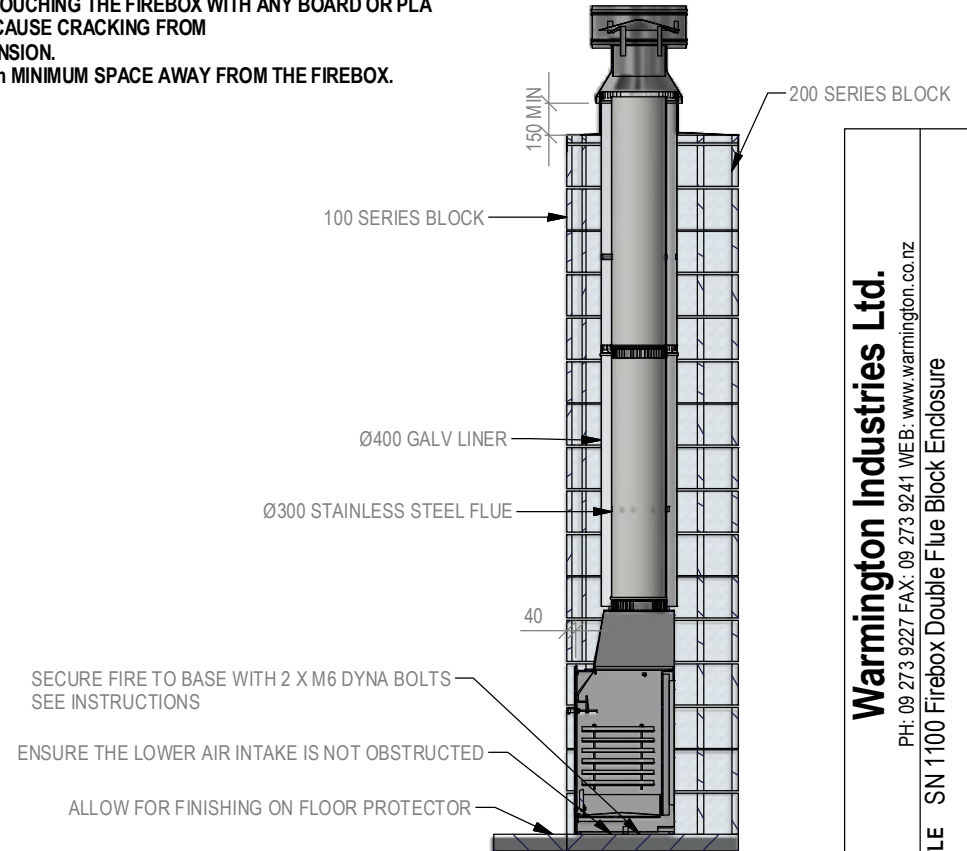

Note:

WARMINGTON CAITEC AIR IS REQUIRED SEE SPECIFIC INSTALL INSTRUCTIONS.

Warmington Industries Ltd.	
PH: 09 273 9227 FAX: 09 273 9241 WEB: www.warmington.co.nz	
TITLE	SN 1100 Firebox Double Flue Block Enclosure
DRAWN	Robert
DATE	26/04/18
SCALE	1/35
REVISION	01