

Warmington Open Wood Fire

SN 1250 Firebox

NOTE: Requires Hebel Enclosure

Fire, Flue System to Comply with ASNZS 2918:2001

Due to continued product improvement, Warmington Ind LTD reserves the right to change product specifications without prior notification.

Read all the instructions carefully before commencing the Installation. Failure to follow these instructions may result in a fire hazard and void the warranty

For Specification See: www.warmington.co.nz

Copyright ©

NOTE: Engineering calculations may be required

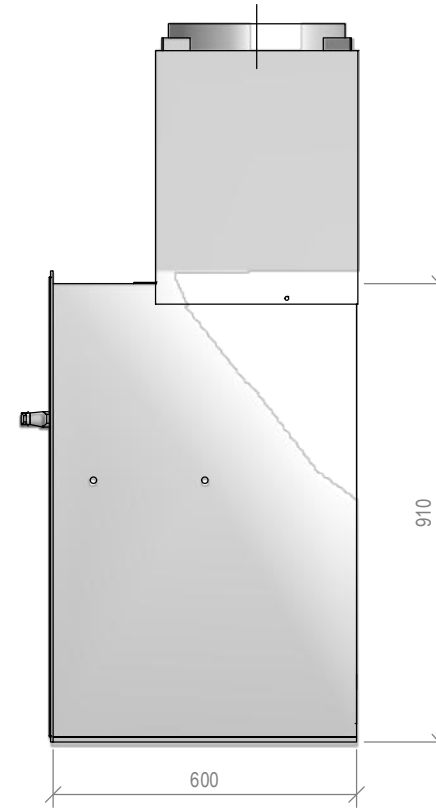
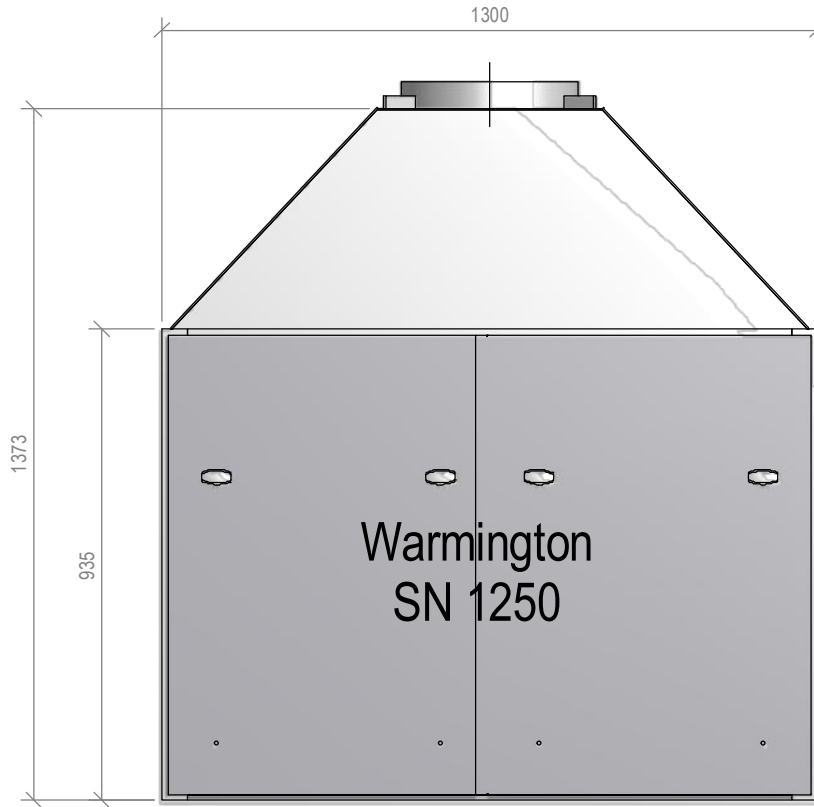

Warmington Industries Ltd.			
PH: 09 273 9227 FAX: 09 273 9241 WEB: www.warmington.co.nz			
TITLE	SN 1250 FIREBOX		
DRAWN	ROBERT	DATE	30/05/11
SCALE	NOT TO SCALE	REVISION	01

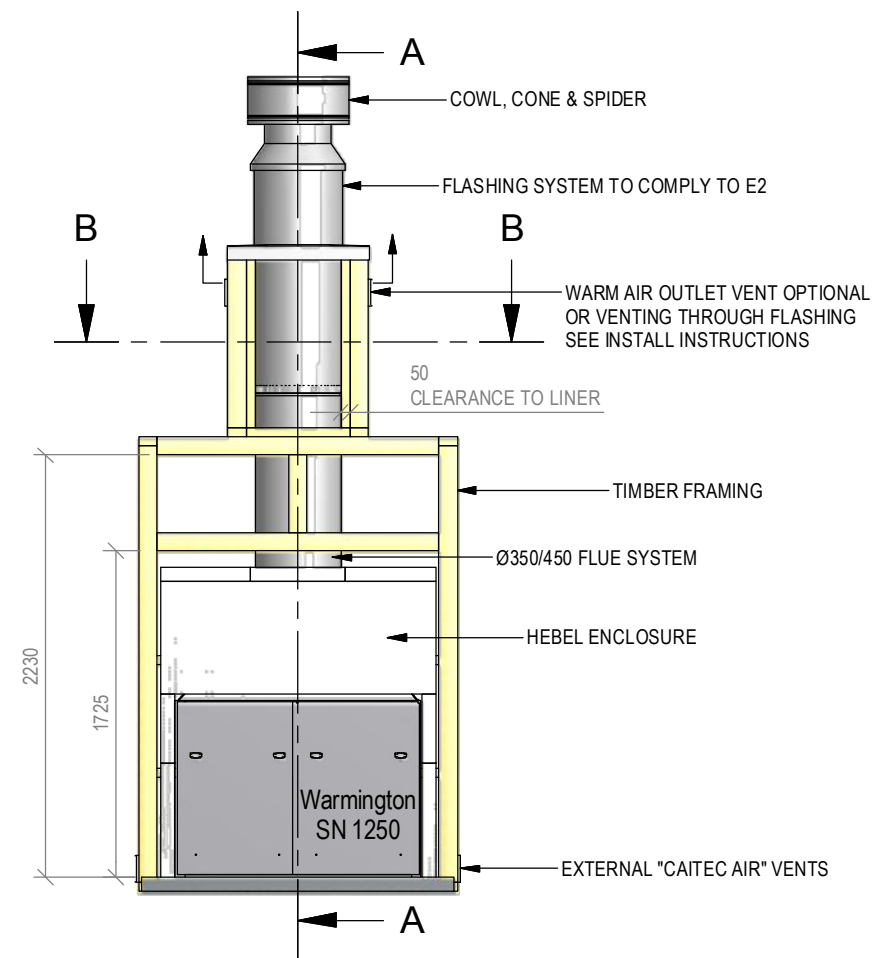
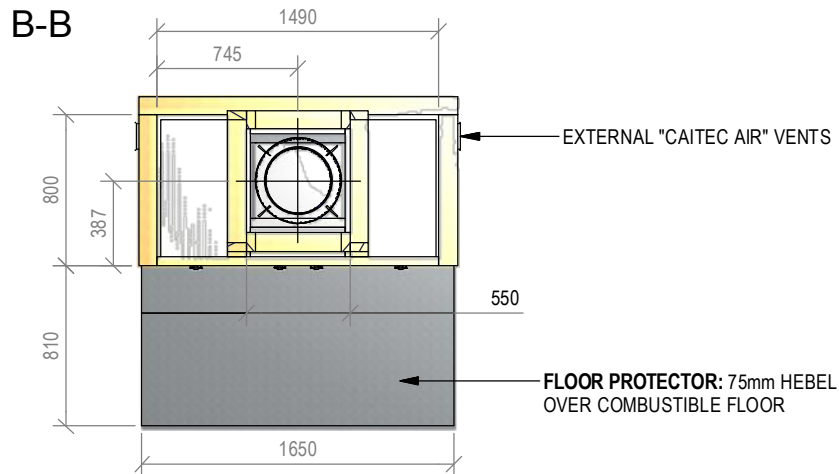

Warmington Open Wood Fire

SN 1250 Timber Framing

NOTE: Requires Hebel Enclosure

Fire, Flue System to Comply with AS/NZS 2918:2001

Due to continued product improvement, Warmington Ind LTD reserves the right to change product specifications without prior notification.

Read all the Instructions carefully before commencing the Installation. Failure to follow these instructions may result in a fire hazard and void the warranty

For Specification See: www.warmington.co.nz

Copyright ©

NOTE: Engineering calculations may be required

IMPORTANT NOTE:

WHERE AN INTERNAL WALL BOARD FINISH IS REQUIRED AROUND THE FIREPLACE, ENSURE ALLOWANCE IS MADE TO PLACE NON COMBUSTIBLE INTERNAL WALL LINING (e.g. PROMINA ETERPAN, SUPALUX) TO COVER THE EXTENT OF THE HEBEL BLOCK SURROUND

DIRECTLY TOUCHING THE FIREBOX WITH ANY BOARD OR PLASTER MAY CAUSE CRACKING FROM HEAT EXPANSION

ALLOW 3mm MINIMUM SPACE AWAY FROM THE FIREBOX

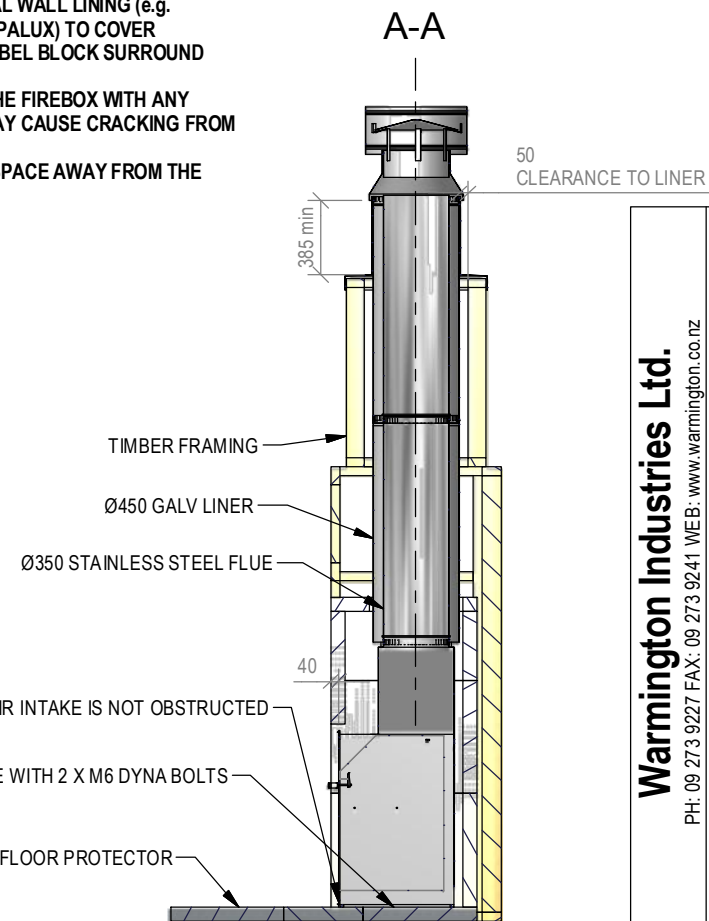

NOTE:

WARMINGTON CAITEC AIR IS REQUIRED
SEE SPECIFIC INSTALL INSTRUCTION

Warmington Industries Ltd.			
PH: 09 273 9227 FAX: 09 273 9241 WEB: www.warmington.co.nz			
TITLE	SN 1250 TIMBER FRAMING	DATE	30/04/18
DRAWN	ROBERT	REVISION	02
SCALE	NOT TO SCALE		

B-B

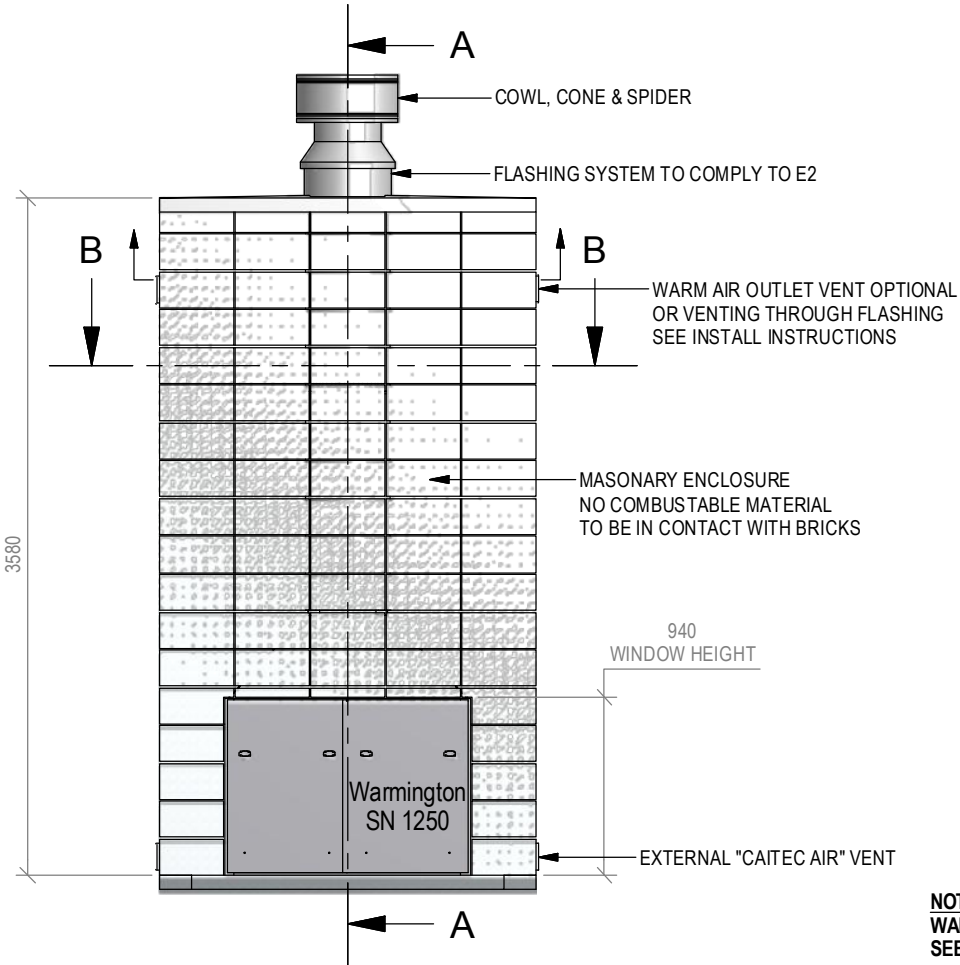
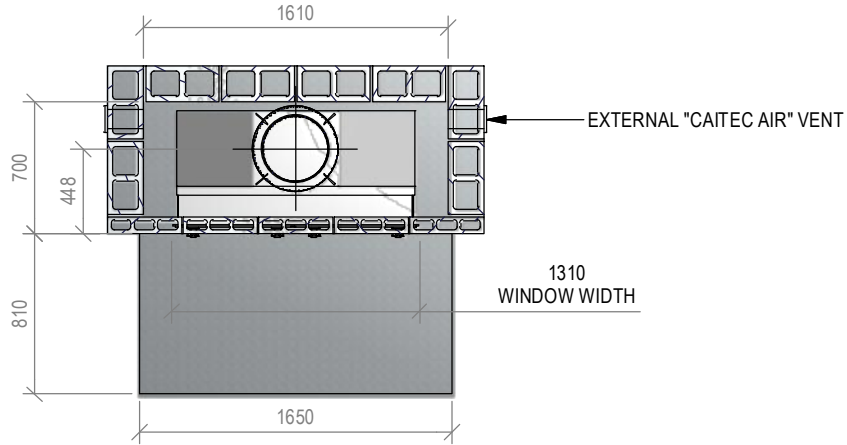

Warrington Open Wood Fire

SN 1250 Block Enclosure

Fire, Flue System to Comply with ASNZS 2918:2001

Due to continued product improvement, Warrington Ind LTD reserves the right to change product specifications without prior notification.

Read all the Instructions carefully before commencing the Installation. Failure to follow these instructions may result in a fire hazard and void the warranty

For Specification See: www.warrington.co.nz

Copyright ©

NOTE: Engineering calculations may be required

IMPORTANT NOTE:

WHERE AN INTERNAL WALL BOARD FINISH IS REQUIRED AROUND THE FIREPLACE, ENSURE ALLOWANCE IS MADE TO PLACE NON COMBUSTIBLE INTERNAL WALL LINING (e.g. PROMINA ETERPAN, SUPALUX) TO COVER THE EXTENT OF THE HEBEL BLOCK SURROUND

DIRECTLY TOUCHING THE FIREBOX WITH ANY BOARD OR PLASTER MAY CAUSE CRACKING FROM HEAT EXPANSION
ALLOW 3mm MINIMUM SPACE AWAY FROM THE FIREBOX

ENSURE THE LOWER AIR INTAKE IS NOT OBSTRUCTED

SECURE FIRE TO BASE WITH 2 X M6 DYNA BOLTS
SEE INSTRUCTIONS

ALLOW FINISHING ON FLOOR PROTECTOR

NOTE:
WARRINGTON CAITEC AIR IS REQUIRED
SEE SPECIFIC INSTALL INSTRUCTION

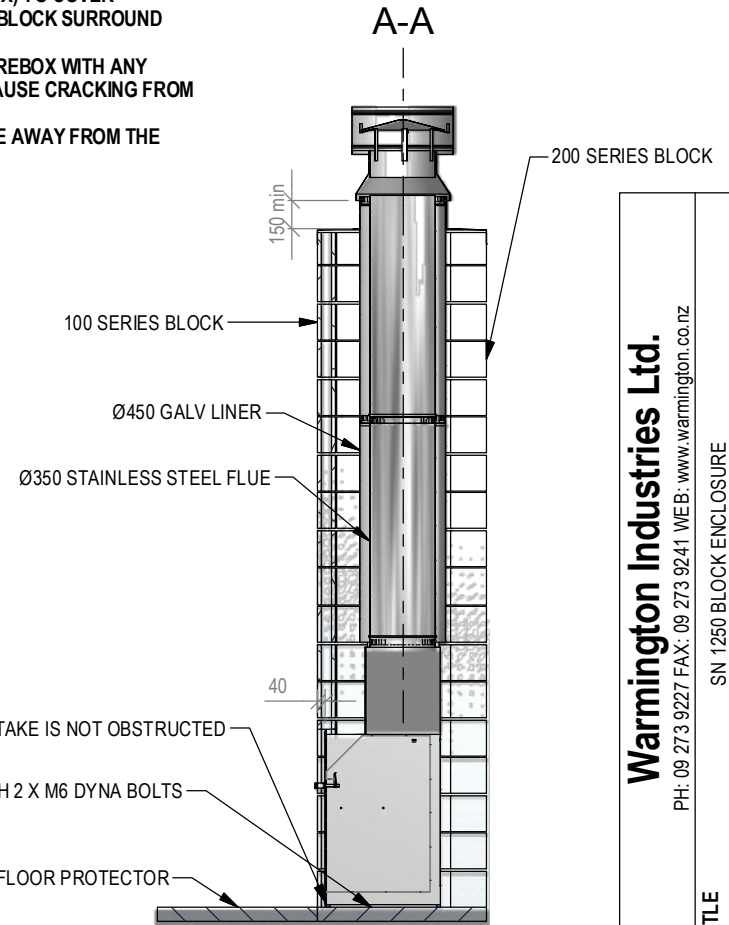

Warrington Industries Ltd.			
PH: 09 273 9227 FAX: 09 273 9241 WEB: www.warrington.co.nz			
TITLE	SN 1250 BLOCK ENCLOSURE	DATE	30/04/18
DRAWN	ROBERT	REVISION	02
SCALE	NOT TO SCALE		