

Warmington Gas Fire

Virage 1200 RH Firebox

Fire, flue system to comply with NZS 5261 / 5262 : 2003

Due to continued product improvement, Warmington Ind LTD reserves the right change product specifications without prior notification.

Read all the the instructions carefully before commencing the installation. Failure to follow these instructions may result in a fire hazard and void the warranty.

Copyright ©

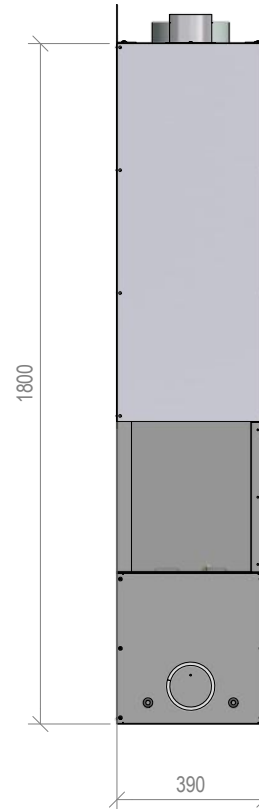
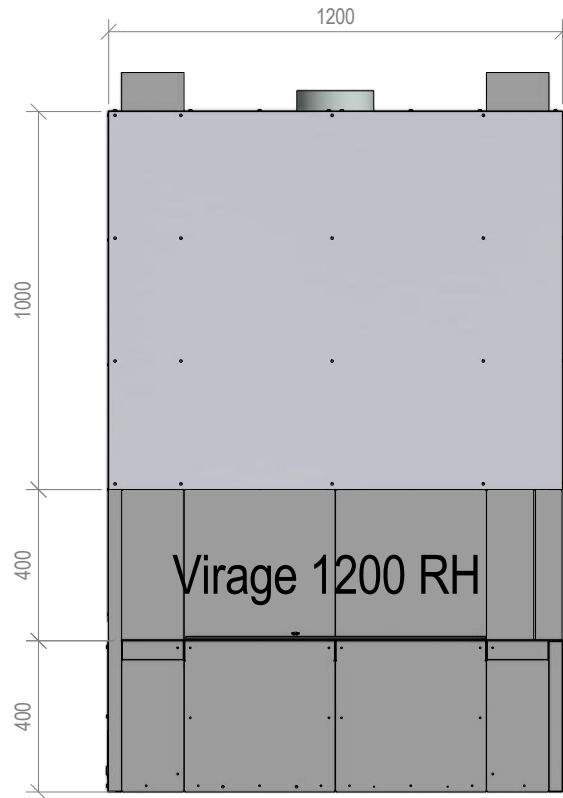

Warmington Industries Ltd.	
PH: 09 273 9227 FAX: 09 273 9241 WEB: www.warmington.co.nz	
TITLE	Virage RH 1200 Firebox
DRAWN	Ben
DATE	12-12-18
SCALE	Not to scale
REVISION	01

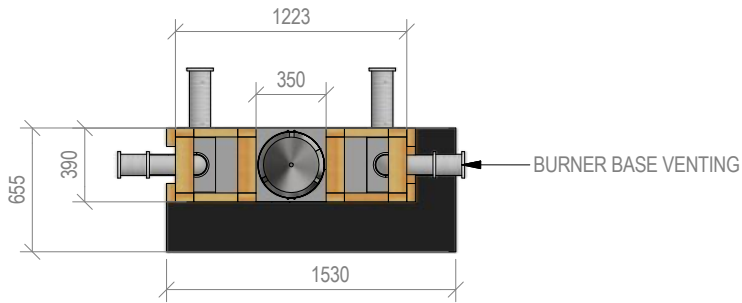

Warmington Gas Fire

Virage 1200 RH Firebox Timber Framing

Fire, flue system to comply with NZS 5261 / 5262 : 2003

Due to continued product improvement, Warmington Ind LTD reserves the right change product specifications without prior notification.

Read all the the instructions carefully before commencing the installation. Failure to follow these instructions may result in a fire hazard and void the warranty.

Copyright ©

IMPORTANT NOTE:

WHERE AN INTERNAL WALL BOARD IS FINISH IS REQUIRED AROUND THE FIREPLACE, ENSURE ALLOWANCE IS MADE TO PLACE NON COMBUSTIBLE INTERNAL WALL LINING (CALCIUM SILICATE BOARD, EQUIVALENT TO 0.136 w/mk) TO COVER THE EXTENT OF THE HEBEL BLOCK SURROUND.

DIRECTLY TOUCHING THE FIREBOX WITH ANY BOARD OR PLASTER MAY CAUSE CRACKING FROM HEAT EXPANSION. ALLOW 3mm MINIMUM SPACE AWAY FROM THE FIREBOX.

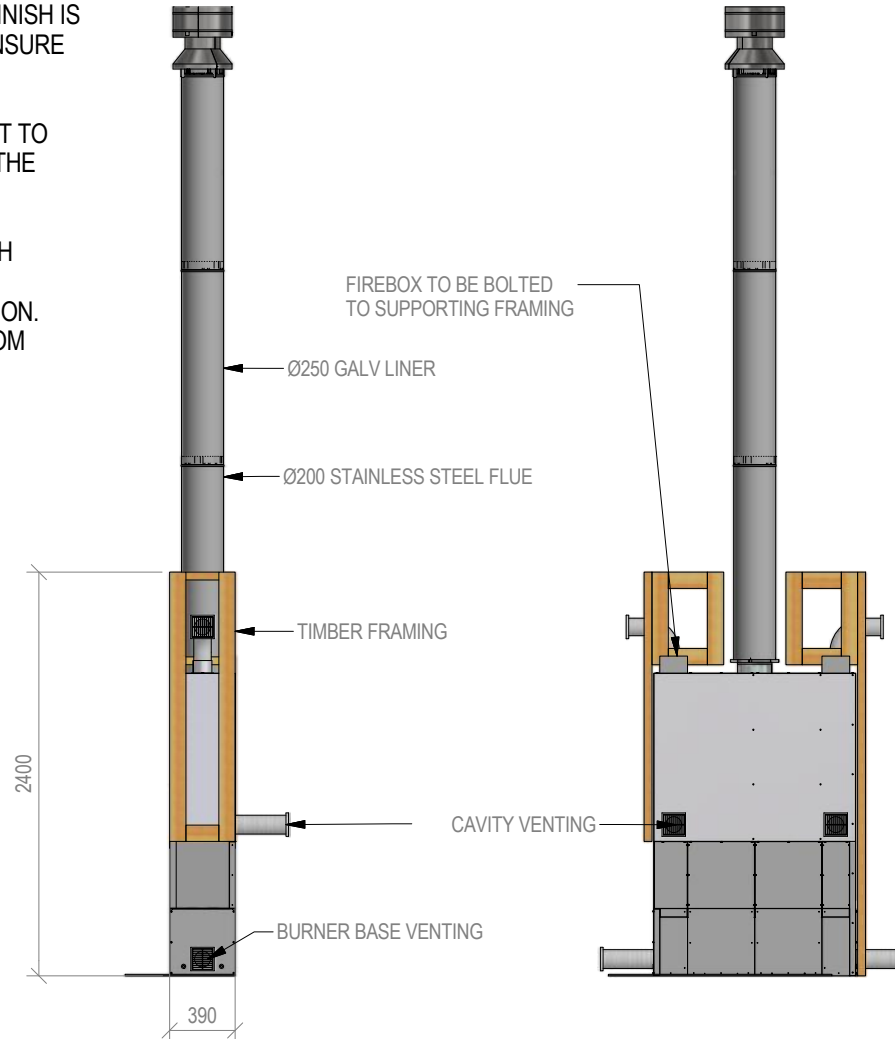
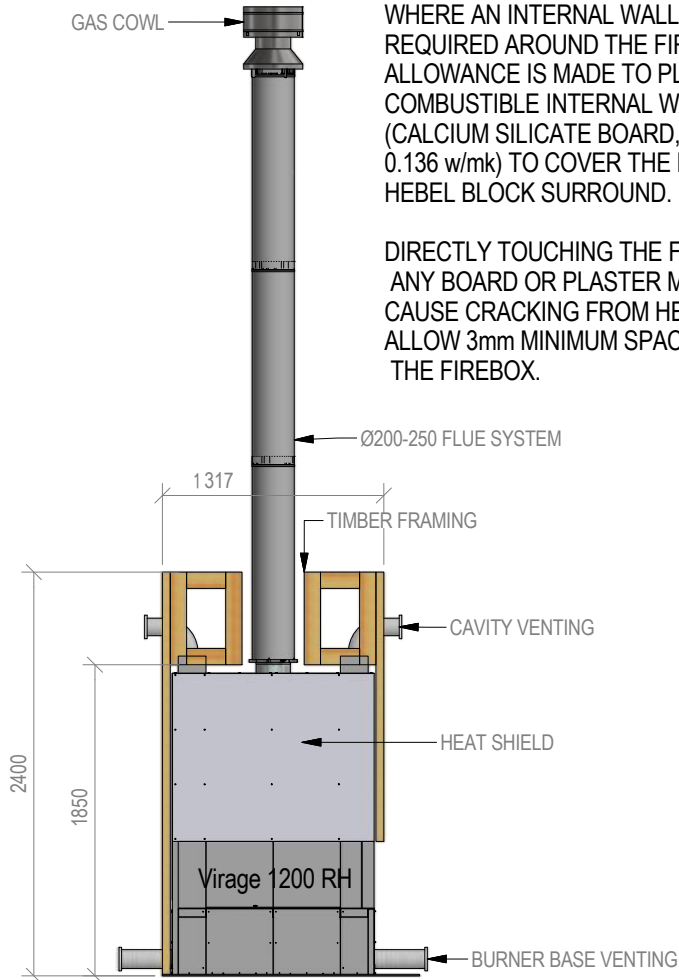

Warmington Industries Ltd.	
PH: 09 273 9227 FAX: 09 273 9241 WEB: www.warmington.co.nz	
TITLE Virage 1200 RH Timber Framing	DATE 10-12-18
DRAWN Ben	REVISION 01
SCALE Not to scale	